



Halsey Taylor[®]
Satisfying Thirsts Since 1912

**HydroBoost[®] In-Wall Bottle Filler
with Filtered Model OVL-II[™] SER-GRN**

MODEL: HTHBWF-OVLSERGRN

**OVL Filtered Fountain
With Bottle Filler**

Rated for Indoor Use Only

GENERAL

In-wall, recessed bottle filling station paired with the bi-level OVL-II[™]SER-GRN refrigerated fountain featuring the high-efficiency SJ8GRN water Chiller. Includes 3000 gallon capacity WaterSentry[®] Plus filter with additional HWF172 1500 gallon filter on bi-level fountain.

HYDROBOOST[®] BOTTLE FILLING STATION

In-wall, recessed design with solid lower panel. Quick fill rate is 1.1 gallons per minute. Includes laminar flow to provide a clean fill with minimal splash and easy maintenance. Equipped with automatic 20-second shut-off timer. User interface design makes touchless operation intuitive. Key plastic components are integrated with silver ion anti-microbial protection to inhibit growth of mold and mildew.

Designed with hinged top and bottom stainless steel panels for easy access and service.

GREEN COUNTER[™]

Visually displays count of plastic bottles saved from waste. (Based on 20 oz. bottles.)

WATERSENTRY[®] PLUS FILTRATION

Equipped with the HWF3000 WaterSentry[®] Plus Filter. Features Quick-Disconnect, 1/4 turn installation and automatic inlet shut-off valve that closes when filter is removed. High grade filter is made with activated carbon and patented ATS lead-removal media. Certified to NSF/ANSI 42 for Chlorine-Class 1, Particulate-Class 1 and Taste and Odor and NSF/ANSI 53 for Lead Reduction. Filter is rated for 3,000 gallon capacity. Green, yellow and red LEDs visually indicate when filter maintenance is required.

Replacement Filters: Available as Singles and Multi-Packs.

Order part numbers:

- 55898C - Single replacement filter
- 55898C - 3PK - Filter three pack
- 55898C - 12PK - Filter twelve pack
- 55898C - 24PK - Filter twenty-four pack
- 55898C - 48PK - Filter forty-eight pack

FOUNTAIN

Oval shape fountains, non-corrosive stainless steel with brushed satin finish and contour-formed basins. Oval fountain shape requires less neck extension and bending for the wheel chair user.

WATER CONSERVATION BUBBLER

Designed to reduce water usage while still providing a satisfying stream. Vandal-resistant SmartFlow[™] water-efficient bubbler is one-piece, heavy-duty with integral hood guard design.

AUTOMATIC STREAM HEIGHT REGULATOR

Self-closing assembly is located inside unit to prevent tampering. Unit resists corrosion and liming. A constant stream height is automatically maintained under line pressures that vary from 20 to 105 psi.

PUSH BAR ACTUATION MECHANISM

Self-closing, semi-circular push bar can be actuated at any point on it's 180° radius.



Stainless Steel Finish Only

MOUNTING FRAMES

Manufactured from corrosion resistant, galvanized steel. Open construction designed for ease of installation. Mounting frames can be shipped in advance for rough-in installation.

SUGGESTED SPECIFICATIONS

Model HTHBWF-OVLSERGRN provides 8.0 gph of 50°F water at 90°F ambient and 80°F inlet water. Bottle filler shall be recessed design and include electronic sensor ctivation with 20-second automatic water shut-off. Shall provide 1.1 gpm flow rate with laminar flow to prevent splashing. Shall include anti-microbial protected plastic components to prevent mold and mildew. Shall include visual display of plastic bottles saved from waste. Fountains shall be oval design with self-closing pushbars and contoured basin. Shall include water conservation bubbler with auto stream height regulator. Shall include high-efficiency SJ8GRN water chiller. Shall meet ADA guidelines for visual and motion disabilities, when properly installed. Shall be lead-free design which meets the Safe Drinking Water Act and is certified to NSF/ANSI 61 and 372, UL 399 and CAN/CSA 22.2 No. 120.

Each HTHBWF-OVLERGRN is shipped in 7 cartons including:

- HYDROBOOST Station with Louvered Lower Panel
- OVL-II-SER-GRN Fountain
- Mounting Frame (2)
- HWF3000 WaterSentry[®] Plus Filter
- Cooling Unit – SJ8GRN (2)

CAPACITIES CHART						UL US	ADA COMPLIANT	NSF/ANSI 61 and 372 Certified	NSF/ANSI 42 and 53 Certified (Filter only)	GreenSpec [®] LISTED
Model	Voltage / Hertz	Chilling** Capacity	F.L. Amps	Rated Watts	Approx. Ship Wt.	UL399 and CAN/CSA 22.2 No. 120 Certified	ADA COMPLIANT	NSF/ANSI 61 and 372 Certified	NSF/ANSI 42 and 53 Certified (Filter only)	GreenSpec [®] Listed
HTHBWF-OVLSERGRN	115V / 60Hz	8 GPH	4.0	260	164 lbs.	•	•	•	•	•

Note: Continued product improvement makes specification subject to change without notice. See Halsey Taylor website for most current spec Sheet.

halseytaylor.com
HALSEY TAYLOR, 2222 Camden Court, Oak Brook, IL 60523

Model HTHBWF-OVLSERGRN OVL-II™ SER-GRN



Halsey Taylor®
Satisfying Thirsts Since 1912

Rated for Indoor Use Only

WALL OPENING

IMPORTANT: It is necessary to create a wall opening 18 3/4" W x 37 3/4" H and 4 1/2" above the floor line.

MOUNTING INSTRUCTIONS

Refer to rough-in for location of plumbing and electrical sources. The support frame is to be installed first. The shelf for the water chiller should be assembled to the wall frame, and then place chiller into position. Hang upper fountain panel to hanger on frame. Fountains are to be attached to panel and wall frame. Water service lines, waste lines and electrical are assembled as required. The bottom panel is attached last, after a final check for leaks and correct functions of fountains and chiller. (For details see the installation instructions.)

Installation required trap to be install in wall. Trap and service stop not included.

OPERATING PRESSURES:

Supply water - 105 psi maximum

ELECTRICAL DATA

Junction box for a (3) wire 10 AMP branch circuit. Standard 120 volt, 60 Hz, single phase.

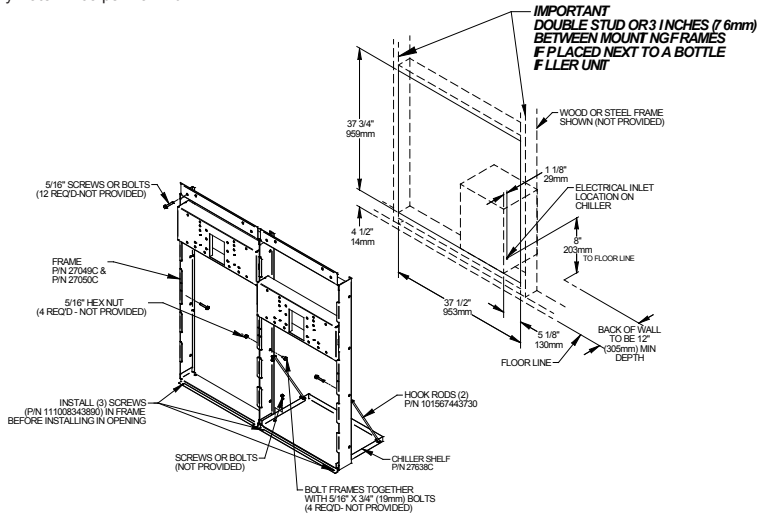

TOP & SIDE VIEWS

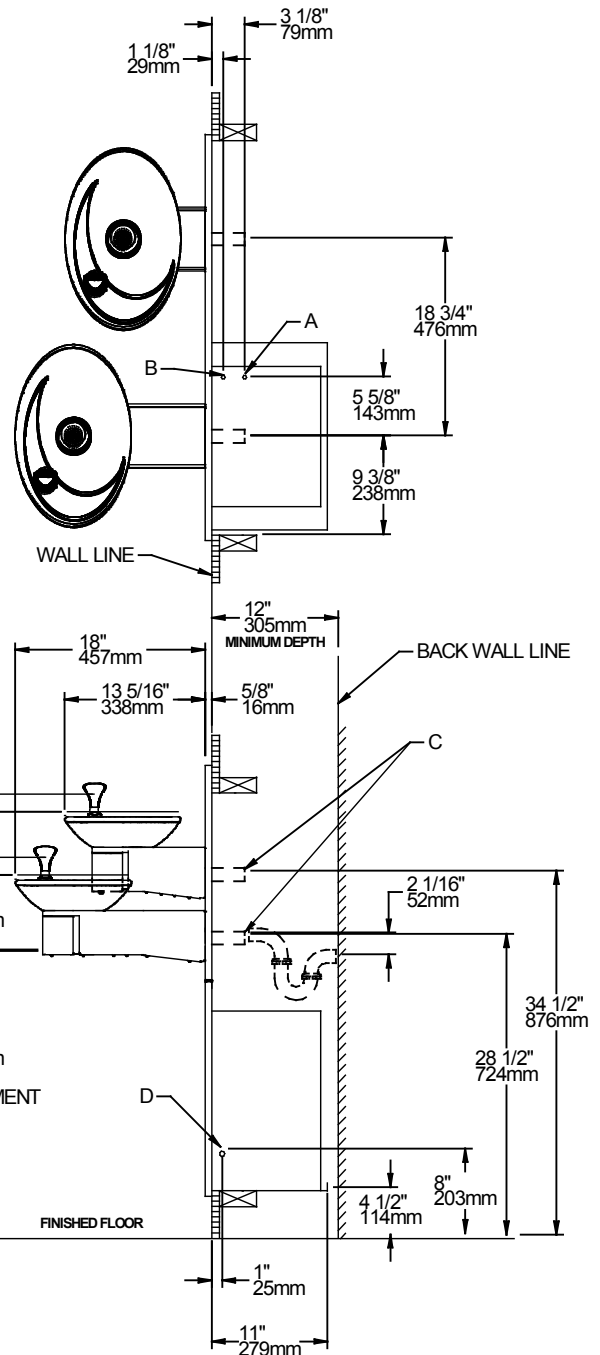

FRONT VIEW

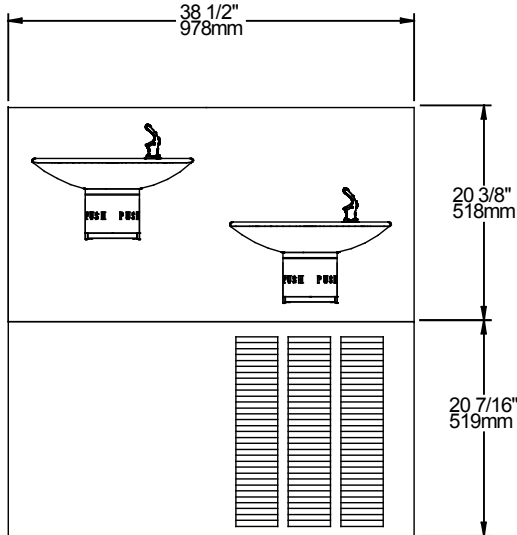

WALL LAYOUT

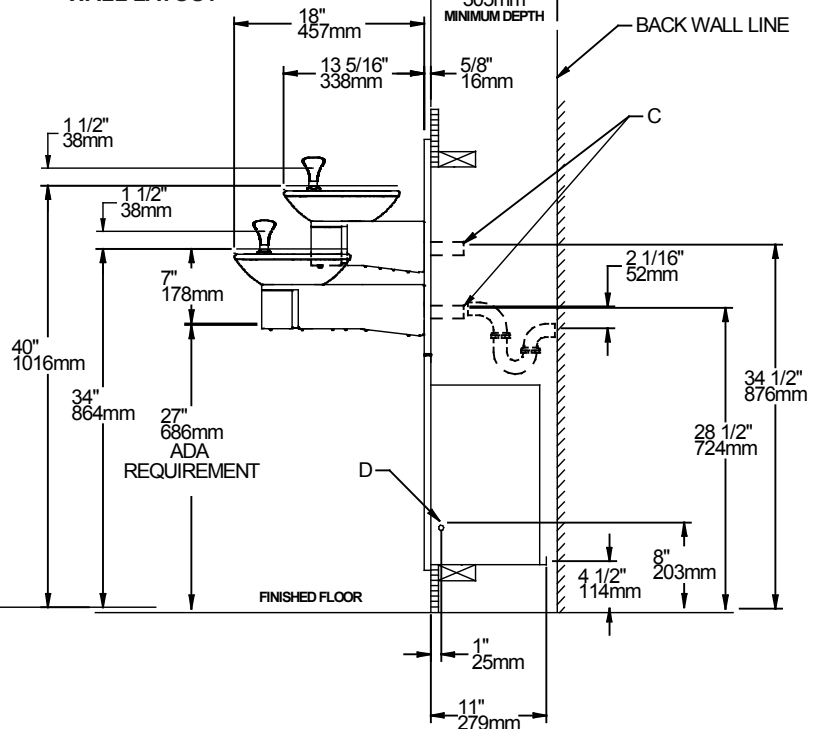

LEGEND:

- A = 1/4" O.D. TUBE CONNECT (CHILLER WATER OUTLET)
- B = 3/8" O.D. TUBE CONNECT (CHILLER WATER INLET) SHUT OFF VALVE BY OTHERS
- C = 1-1/2" WASTE TUBE (ELBOW & TRAP NOT PROVIDED)
- D = ELECTRICAL INLET

Halsey Taylor®